

Expander2

P/N: 81P-0101

Rev –
8 AUG 2019

Graves Electronics, LLC

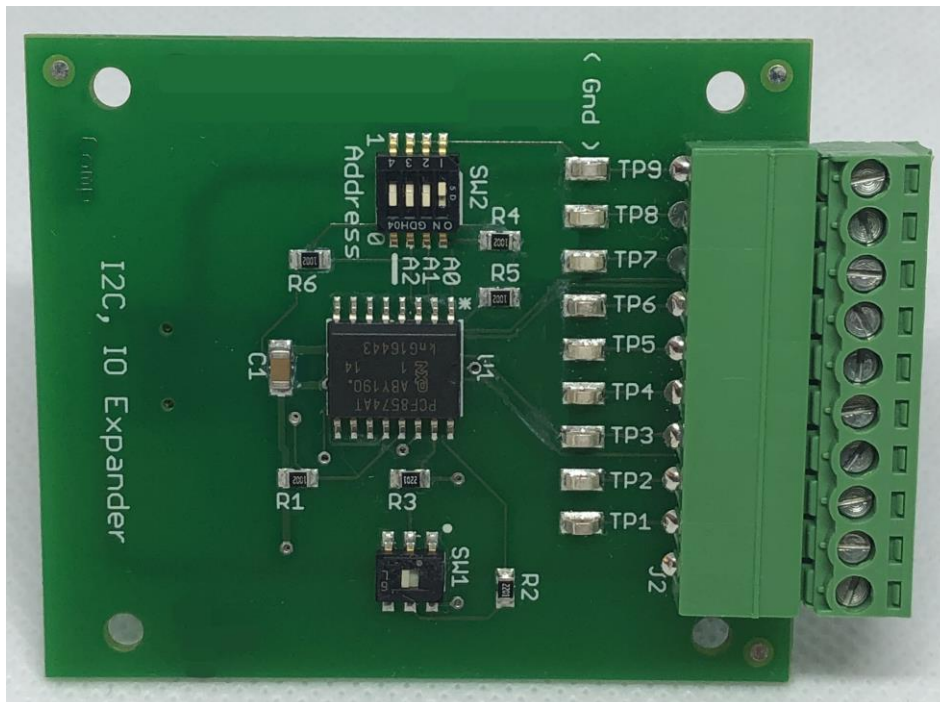

Symbols used in this manual:



CAUTION: This indicates a situation where if certain requirements are not followed, damage or unsafe conditions may occur.



WARNING: This indicates a situation where if certain requirements are not followed, damage or unsafe conditions **WILL** occur.



If you are having problems getting the board to work properly, BEFORE calling the factory, please visit the FAQ page at www.graveselectronicsapps.com/FAQ, and/or thoroughly read section 9.0 of this manual. If you are still having problems, please download the test code from www.graveselectronicsapps.com/downloads and run the code. If you are still having issues after reading the help section and trying the test code, please contact the factory. We kindly ask that you please e-mail us at graveselectronics@gmail.com. Please clearly state your problem along with a call back phone number. One of our technicians will call you after we have reviewed your issue and have come up with some solutions.

This manual, as well as test code, can be downloaded at www.graveselectronicsapps.com/downloads.

Contact Information:

Customer Service, Sales, Technical Assistance

graveselectronics@gmail.com or call us at 860-295-3074

Warranty & Legal:

Graves Electronics, LLC warrants that its products conform to the stated specifications. Graves Electronics, LLC warrants that its products will be free from material and manufacturing defects for the life of the product. Graves Electronics, LLC shall not be liable for any defects that are caused by neglect, misuse, or mistreatment by the customer, or third party, including improper installation or testing, or for any products that have been altered or modified in any way by the customer or a third party. Graves Electronics, LLC products are not authorized for use in safety-critical applications where a failure of the product would reasonably be expected to cause severe personal injury or death. Safety-critical applications include, without limitation, life support devices and systems, equipment or systems for the operation of nuclear facilities, and weapons systems. Graves Electronics, LLC products are neither designed nor intended for use in military, aerospace, or automotive applications or environments. The customer acknowledges that use of Graves Electronics, LLC products is entirely at the customer's risk, and the customer agrees to defend, indemnify and hold harmless Graves Electronics, LLC from any and all damages, claims, suits, or expenses resulting from such use. The customer acknowledges and agrees that the customer is solely responsible for compliance with all statutory, legal, regulatory, and safety related requirements in regards to the usage of Graves Electronics, LLC products. In no event shall Graves Electronics, LLC be liable to the customer or any third party for any special, collateral, indirect, punitive, incidental, consequential, or exemplary damage in connection with, or arising from, the customer's software. The customer agrees to defend, indemnify and hold harmless Graves Electronics, LLC from any and all damages, claims, suits, or expenses resulting from said customer's software. Customer acknowledges that Graves Electronics, LLC reserves the right to change specifications on any product at any time without notice.

This document, related documents, drawings, technical specifications, designs, or operational information is the property of Graves Electronics, LLC

Table of Contents

1.0	Overview	1
2.0	The Chip.....	1
2.1	I/O.....	1
	<i>Table 2.1.</i>	1
2.2	Address	2
	<i>Table 2.2</i>	2
2.3	I ² C.....	2
	<i>Table 2.3.</i>	3
2.3.1	I ² C Pull-Up Resistors	3
2.4	+5V and Ground on J2	3
3.0	Interrupt Output Pin (/INT).....	3
	<i>Table 3.</i>	4
4.0	Installing the Module	4
4.1	Pluggable Terminal Block (J2).....	4
5.0	Electrical Specifications.....	4
6.0	Block Diagram	4
7.0	Mechanical	6

1.0 Overview

The Expander2 is an easy to use I/O expander module that increases the functionality of the 81 controller board. It plugs into either of the module ports on the 81 controller board. The Expander2 module uses the I²C bus to communicate with the microcontroller on the 81 board. It has DIP switches which enable address selection, as well as to engage or disengage pull-up resistors for the I2C bus. The module interfaces to the outside world via the 10-position pluggable terminal block.

2.0 The Chip

The Expander2 is based around the NXP PCF8574 chip. The chip contains eight, quasi-bidirectional ports, three addressing ports, and an active LOW interrupt output. For a further, in-depth explanation of the PC8574 chip, including its operation, how to read and write to the ports, how the interrupt output functions, and for timing diagrams, please consult the [PC8574 datasheet](#).

2.1 I/O

Each I/O pin from the PCF8574 can be independently controlled and is capable of sourcing up to 25 mA. Each I/O pin will sink up to 20 mA (guaranteed minimum sinking current of 10 mA), providing an external pull-up/pull-down resistor is used. Each I/O pin is mapped to the 10-position pluggable header, J2. There are test points for each I/O port. Table 2.1 shows how the port pins, test points, and header are mapped.



CAUTION: If using the pins to source (output), NO external pull-up/pull-down resistor is required. The external pull-up/pull-down resistor is ONLY required if using the pins to sink (input).

Table 2.1.

J2	Test Point	I/O Port
1		+5V (V _{DD})
2	TP1	P0
3	TP2	P1
4	TP3	P2
5	TP4	P3
6	TP5	P4
7	TP6	P5
8	TP7	P6
9	TP8	P7
10	TP9	V _{SS} (Ground)

2.2 Address

The PCF8574 has three ports dedicated to addressing it. The module provides an easy method of addressing by way of DIP switch SW2. On one side of the switch is V_{DD} , labeled as “1” and the other side is V_{SS} , labeled as “0”. A0, A1, and A2 are the three addressing ports and are labeled. SW2 is a four position DIP switch with the fourth position not being connected to anything. Table 2.2 shows the hexadecimal address obtained by the various address switch combinations.

Table 2.2

Switch SW2			Address Byte Value	
A0	A1	A2	Write	Read
0	0	0	0x40	0x41
1	0	0	0x42	0x43
0	1	0	0x44	0x45
1	1	0	0x46	0x47
0	0	1	0x48	0x49
1	0	1	0x4A	0x4B
0	1	1	0x4C	0x4D
1	1	1	0x4E	0x4F

2.3 I²C

The module communicates with the 81 board microcontroller via the I²C bus. The SCL and SDA lines are mapped to J1, located on the underside of the module. Table 2.3 shows the pin configuration of J1. For more information on the I²C bus, please consult NXP document [UM10204](#).

Table 2.3.

J1	Function	J1	Function
1	V _{DD} (+5V)	6	N.C.
2	V _{SS} (Ground)	7	N.C.
3	N.C. (No Connect)	8	SDA
4	SCL	9	N.C.
5	/INT	10	N.C.

2.3.1 I²C Pull-Up Resistors

In order for the I²C bus to work correctly, it must have pull-up resistors on the SDA and SCL lines. The module makes that easy through the use of switch SW1. When the switch is in the “On” position (as labeled on the module), two 2.2K Ohm resistors are switched in to the I²C bus; one on the SDA line and one on the SCL line. When the switch is in the “Off” position, the pull-up resistors are switched out of the circuit. If only one module is being used, it must have the pull-up resistors switched on. If two modules are being used, only one module needs to have the I²C pull-up resistors switched on. It does not matter which module has the resistors switched on.



CAUTION: Failure to switch on the I²C pull-up resistors could result in erratic operation of the I²C bus, and consequently, erratic operation of the module!



CAUTION: If using two modules, switching on the I²C pull-up resistors on BOTH modules could result in erratic operation of the I²C bus, and consequently, erratic operation of the module! When using two modules, switch on only ONE I²C pull-up!

2.4 +5V and Ground on J2

Pluggable header J2 has +5V and Ground on it to facilitate ease of wiring switches, sensors, and such to the expander module. The +5V is on pin 1 of J2 and Ground is on pin 10 (see Table 2.1). There is also a ground test point, TP9.

The +5V is designed to supply no more than 100 mA of current to a load.



WARNING: Exceeding 100 mA on the +5V output on J2 can drag down the main board supply causing erratic operation!

3.0 Interrupt Output Pin (/INT)

The PCF8574 has an open-drain output interrupt (/INT) pin that is mapped to pin 5 on J1 (see Table 2.3). This output is active LOW. It is held high by a 10K Ohm pull-up resistor on the module. Table 3.0 shows how pin 5 is mapped to the 81 board microcontroller.

Table 3.

Module Port	Microcontroller Port
Module 1	RC3
Module 2	RC2

4.0 Installing the Module

Installation of the Expander2 module is extremely easy. First, decide which module port on the 81 board the module will plug into. The module communicates over I²C to the microcontroller, so for communications purposes, it does not matter which module port is utilized. Pick the port that is most convenient for mechanical or aesthetic reasons. Remove the black protective header cap off of the header on the main board. Carefully align J1 of the module with the header on the module port. Push down until the module is fully seated onto the header. The module is fully seated when the module is touching the four standoffs on the module port. Use the four 4-40 x ¼ Philips pan head screws supplied with the module to secure the module. The tightening torque is a minimum of 2.6 in.-lbs. and a maximum of 16.6 in.-lbs. **DO NOT EXCEED 16.6 IN-LBS!**

4.1 Pluggable Terminal Block (J2)

The pluggable terminal block, J2, is how the module interfaces to the outside world. The pluggable block is Phoenix Contact part number 1840447. The plug can accept wire from 30 to 14 AWG. The screw is a M2 and tightening torque is 1.95 to a maximum of 2.21 in.-lbs.

5.0 Electrical Specifications

Symbol	Parameter	Condition	Min	Max	Unit
I _o	Output Current	Per pin	-	25	mA
I _i	Input Current	Per pin	-	20	mA
V _o	Output Voltage	Per pin	-	5.5	V
V _i	Input Voltage	Per pin	-	5.5	V
C _o	Output Capacitance	Per pin	-	10	pF
C _i	Input Capacitance	Per pin	-	10	pF
T _o	Operating Temperature		-40	+85	C

6.0 Block Diagram

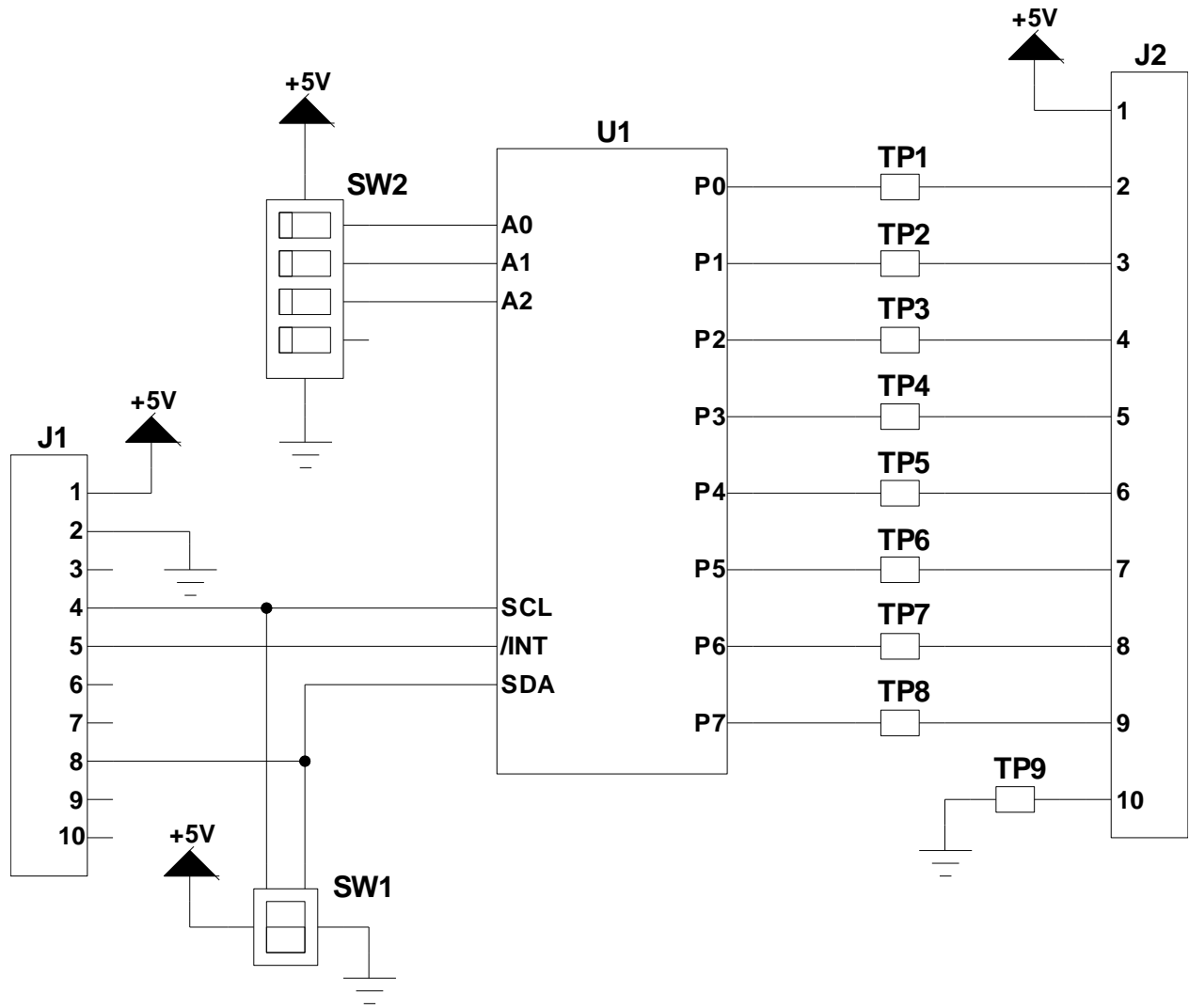

7.0 Mechanical

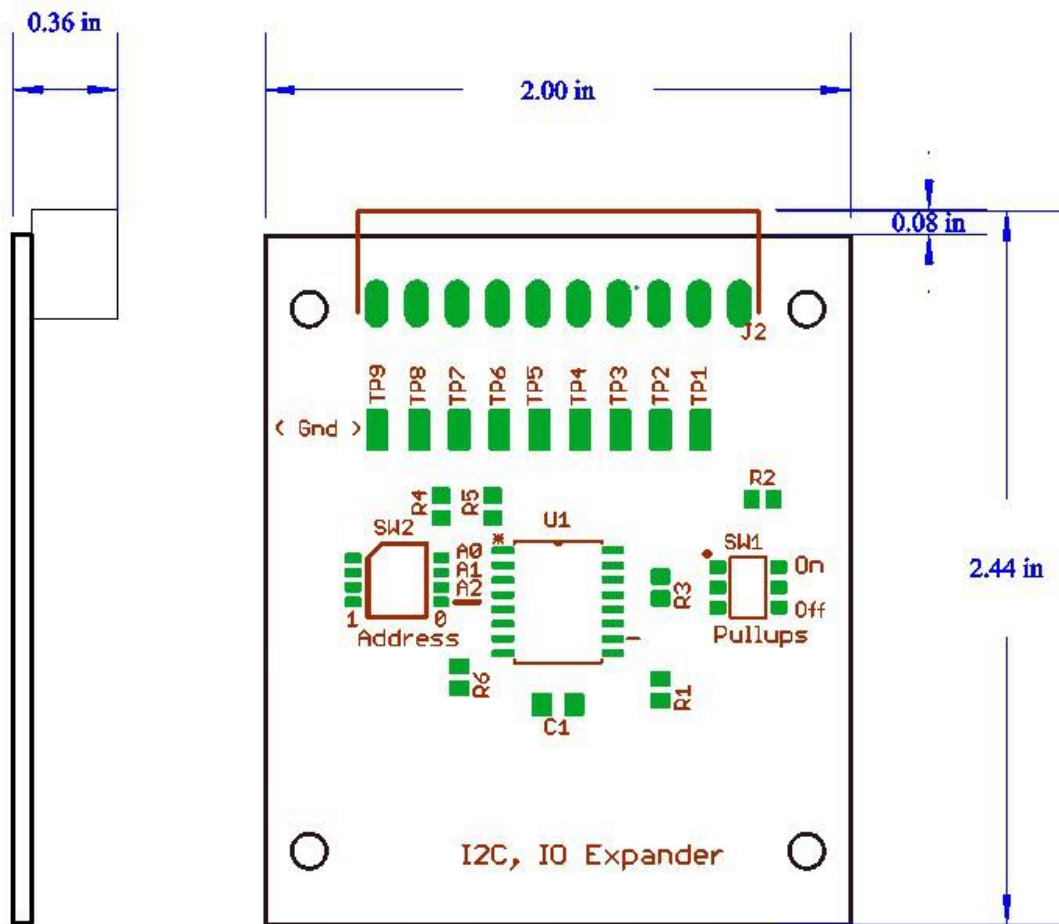

Please note: Side view only shows highest component above the module mounting surface.